



# LP Series-General Purpose LP12-3.5(12V3.5Ah)



## Specifications

Rated Voltage	12V	
Nominal Capacity	3.5Ah	(C <sub>20</sub> , 1.75V/cell)
Dimension	Length	134±2mm (5.28 inches)
	Width	67±1mm (2.64 inches)
	Container Height	59.5±1mm (2.34 inches)
	Total Height	65.5±1mm (2.58 inches)
Approx Weight	1.19 Kg (2.62 lbs)	
Terminal	T1	
Container Material	ABS	
Rated Capacity (25°C)	3.50 Ah	(20hr, 0.175A, 1.75V/cell)
	3.31 Ah	(10hr, 0.331A, 1.75V/cell)
	3.01 Ah	(5hr, 0.602A, 1.75V/cell)
	2.62 Ah	(3hr, 0.872A, 1.75V/cell)
	2.15 Ah	(1hr, 2.15A, 1.60V/cell)
Max. Discharge Current	53A (5s)	
Internal Resistance (25°C)	Approx 40mΩ	
Operating Temp. Range	Discharge	-15 ~ 50°C (5 ~ 122°F)
	Charge	-20 ~ 40°C (-4 ~ 104°F)
	Storage	-15 ~ 40°C (5 ~ 104°F)
Nominal Operating Temp. Range	25±3°C (77±5°F)	
Cycle Use	Initial Charging Current less than 1.05A. Voltage 14.4V~15.0V at 25°C(77°F)Temp. Coefficient -30mV/°C	
	Initial Charging Current less than 1.05A. Voltage 13.5V~13.8V at 25°C(77°F)Temp. Coefficient -20mV/°C	
Standby Use	Initial Charging Current less than 1.05A. Voltage 13.5V~13.8V at 25°C(77°F)Temp. Coefficient -20mV/°C	
Effect of temp. to Capacity	40°C (104°F)	103%
	25°C (77°F)	100%
	0°C (32°F)	86%
Self Discharge	LP series batteries may be stored for up to 6 months at 25°C(77°F) and then a freshening charge is required. For higher temperatures the time interval will be shorter.	



## Layout

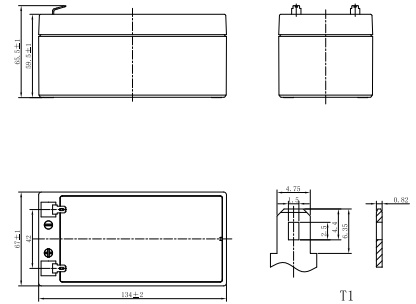

## Constant Current Discharge (Amperes) at 25 °C (77°F)

F.V/Time	5min	10min	15min	20min	30min	45min	1h	1.5h	2h	3h	4h	5h	6h	8h	10h	20h
1.85V/cell	10.6	7.36	5.72	4.66	3.43	2.47	1.94	1.45	1.15	0.845	0.681	0.586	0.502	0.396	0.323	0.171
1.80V/cell	11.4	7.80	6.01	4.84	3.53	2.54	1.99	1.48	1.18	0.859	0.691	0.595	0.510	0.401	0.328	0.173
1.75V/cell	12.0	8.11	6.21	4.98	3.62	2.59	2.03	1.50	1.20	0.872	0.700	0.602	0.516	0.406	0.331	0.175
1.70V/cell	12.5	8.44	6.41	5.12	3.72	2.65	2.07	1.53	1.21	0.885	0.710	0.611	0.522	0.410	0.334	0.176
1.67V/cell	13.0	8.67	6.57	5.23	3.78	2.69	2.10	1.55	1.23	0.894	0.717	0.616	0.527	0.413	0.337	0.178
1.60V/cell	13.8	9.04	6.80	5.38	3.88	2.76	2.15	1.58	1.25	0.910	0.729	0.626	0.534	0.419	0.341	0.180

## Constant Power Discharge (Watts/cell) at 25 °C (77°F)

F.V/Time	5min	10min	15min	20min	30min	45min	1h	1.5h	2h	3h	4h	5h	6h	8h	10h	20h
1.85V/cell	20.0	14.0	11.0	8.97	6.62	4.79	3.78	2.82	2.26	1.66	1.34	1.16	0.99	0.784	0.643	0.342
1.80V/cell	21.3	14.7	11.4	9.28	6.80	4.90	3.86	2.87	2.29	1.68	1.36	1.17	1.01	0.795	0.651	0.346
1.75V/cell	22.2	15.2	11.7	9.48	6.94	4.99	3.93	2.92	2.33	1.71	1.38	1.19	1.02	0.803	0.657	0.350
1.70V/cell	23.0	15.7	12.1	9.70	7.09	5.08	3.99	2.96	2.36	1.73	1.39	1.20	1.03	0.810	0.663	0.353
1.67V/cell	23.6	16.1	12.3	9.88	7.20	5.15	4.04	2.99	2.38	1.74	1.40	1.21	1.04	0.816	0.668	0.356
1.60V/cell	24.6	16.5	12.7	10.1	7.36	5.24	4.11	3.04	2.42	1.77	1.42	1.23	1.05	0.827	0.675	0.359



# LP Series-General Purpose LP12-3.5(12V3.5Ah)



## Applications

- All purpose
- Uninterruptable Power Supply (UPS)
- Electric Power System (EPS)
- Emergency backup power supply
- Alarm and security system
- Communication power supply
- DC power supply
- Auto control system

## General Features

- 5 years design life(25°C)
- Special exhaust structure and sealing technology, safe and reliable, flexible installation, convenient maintenance
- PbCaSn alloy for plate grids: less gassing, less self-discharging
- High quality AGM separator: extend cycle life and prevent micro short circuit
- High purity raw material: ensure low self discharge rate

## Standards

- Compliance with IEC 60896 standards, EU Battery Directive
- UL, CE Certified
- Manufactured in Leoch®IATF16949, ISO45001,ISO 9001 and ISO 14001 certified production facilities

## Discharge Characteristics

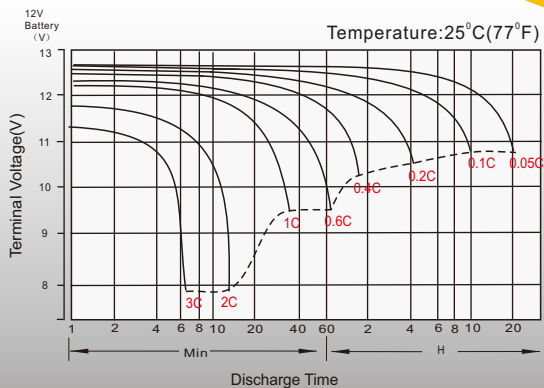

## Float Charging Characteristics

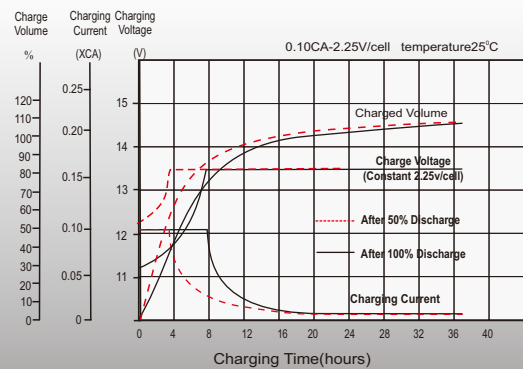

## Temperature Effects in Relation to Battery Capacity

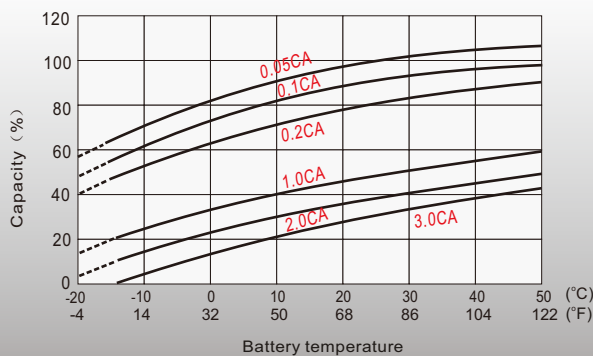

## Effect of Temperature on Long Term Float Life

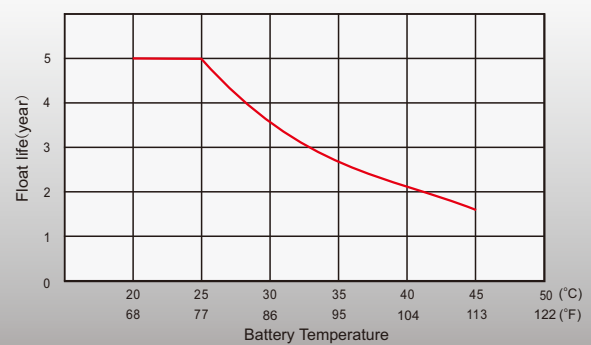

distributed by: Power Storage Deutschland GmbH

+49 (0)6081 96582-0

info@psd-power.de

www.psd-power.de



[Http://www.leoch.com](http://www.leoch.com)

© 2021 LEOCH. All rights reserved.  
Trademarks and logos are the property of LEOCH and its affiliates unless otherwise noted.  
Subject to revisions without prior notice.

Publication No.: LB-LP12-3.5-PD-EN-V2.0-202106